

Amarillo Series Fan Drive

Model 1814

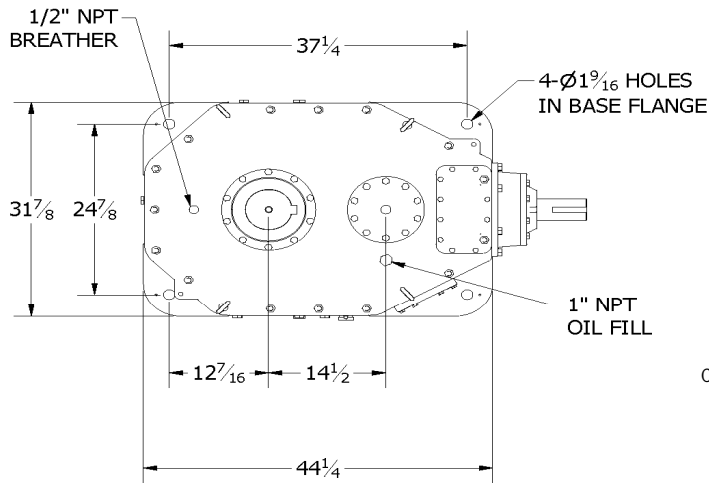

HORIZONTAL KEYWAY: 3/4 x 3/8
 VERTICAL KEYWAY: 1 1/2 x 3/4
 NORMAL ROTATION: BOTH SHAFTS CLOCKWISE

Amarillo Gear Company LLC reserves the right to make design modifications to our gear drives that may change the given dimensions. The dimensions shown in this document may not exactly reflect the dimensions of gear drives currently being offered. Request a *certified dimension print* for construction use.

OIL PUMP (OPTION) MINIMUM CLEARANCE:
 LOCATED BENEATH THE INTERMEDIATE SHAFT.
 CONTACT THE FACTORY FOR ADDITIONAL INFORMATION AND
 A CERTIFIED DIMENSION PRINT

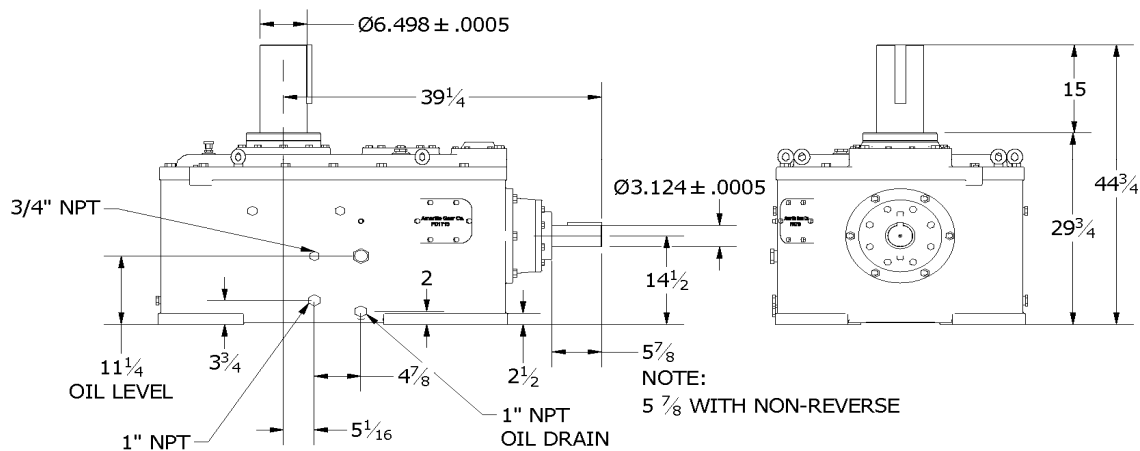
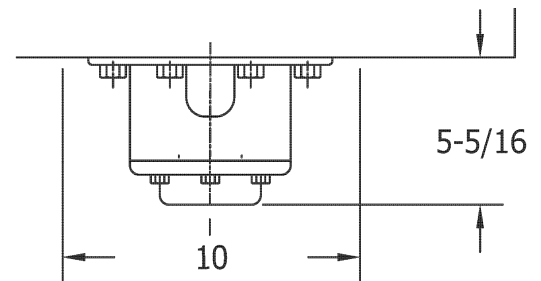

SERVICE HORSEPOWER RATINGS (2.0 SERVICE FACTOR)

Input (RPM)	Nominal Ratio									
	12	13	14	15	15.5	16	17	18	19	20
1750	454	419	389	363	356	345	324	309	291	279
1450	376	346	322	301	295	286	268	255	241	231
1160	301	277	258	241	236	229	215	204	192	184

THRUST CAPACITY: _____ 17000 lbs.
 OIL TYPE: _____ ISO 220 / AGMA 5 or 5S / No EP additives
 OIL CAPACITY: _____ 31 gallons (117 L)
 WEIGHT, DOMESTIC SHIPPING: _____ 4270 lbs.
 WEIGHT, EXPORT SHIPPING w/EXPORT BOX: _____ 4530 lbs.
 EXPORT BOX DIMENSIONS (L x W x H): _____ 65 x 50 x 51 (inches)